

ICS 23.040.10; 77.140.75

English version

**Seamless steel tubes for pressure purposes - Technical delivery
conditions - Part 3: Alloy fine grain steel tubes
(includes amendment A1:2004)**

Tubes sans soudure en acier pour service sous pression -
Conditions techniques de livraison - Partie 3: Tubes en
acier allié à grain fin
(inclut l'amendement A1:2004)

Nahtlose Stahlrohre für Druckbeanspruchungen -
Technische Lieferbedingungen - Teil 3: Rohre aus legierten
Feinkornbaustählen
(enthält Änderung A1:2004)

This European Standard was approved by CEN on 25 April 2002; amendment A1 was approved by CEN on 2 January 2004.

CEN members are bound to comply with the CEN/CENELEC Internal Regulations which stipulate the conditions for giving this European Standard the status of a national standard without any alteration. Up-to-date lists and bibliographical references concerning such national standards may be obtained on application to the Management Centre or to any CEN member.

This European Standard exists in three official versions (English, French, German). A version in any other language made by translation under the responsibility of a CEN member into its own language and notified to the Management Centre has the same status as the official versions.

CEN members are the national standards bodies of Austria, Belgium, Cyprus, Czech Republic, Denmark, Estonia, Finland, France, Germany, Greece, Hungary, Iceland, Ireland, Italy, Latvia, Lithuania, Luxembourg, Malta, Netherlands, Norway, Poland, Portugal, Slovakia, Slovenia, Spain, Sweden, Switzerland and United Kingdom.



EUROPEAN COMMITTEE FOR STANDARDIZATION
COMITÉ EUROPÉEN DE NORMALISATION
EUROPÄISCHES KOMITEE FÜR NORMUNG

Management Centre: rue de Stassart, 36 B-1050 Brussels

Contents

Foreword	3
1 SCOPE	4
2 NORMATIVE REFERENCES	4
3 TERMS AND DEFINITIONS	5
4 SYMBOLS	6
5 CLASSIFICATION AND DESIGNATION.....	6
5.1 Classification	6
5.2 Designation	6
6 INFORMATION TO BE SUPPLIED BY THE PURCHASER.....	7
6.1 Mandatory information.....	7
6.2 Options	7
6.3 Examples of an order	8
7 MANUFACTURING PROCESS	8
7.1 Steelmaking process.....	8
7.2 Deoxidation process	8
7.3 Tube manufacture and delivery conditions	8
8 REQUIREMENTS.....	9
8.1 General	9
8.2 Chemical composition	9
8.3 Mechanical properties.....	10
8.4 Appearance and internal soundness.....	17
8.5 Straightness	17
8.6 Preparation of ends.....	17
8.7 Dimensions, masses and tolerances.....	18
9 INSPECTION.....	22
9.1 Types of inspection	22
9.2 Inspection documents.....	23
9.3 Summary of inspection and testing.....	23
10 SAMPLING	25
10.1 Frequency of tests.....	25
10.2 Preparation of samples and test pieces.....	26
11 TEST METHODS.....	27
11.1 Chemical analysis.....	27
11.2 Tensile test.....	27
11.3 Flattening test	28
11.4 Ring tensile test	28
11.5 Drift expanding test	28
11.6 Ring expanding test	29
11.7 Impact test.....	29
11.8 Leak tightness test	29
11.9 Dimensional inspection	30
11.10 Visual examination	30
11.11 Non-destructive testing	30
11.12 Material identification.....	31
11.13 Retests , sorting and reprocessing	31
12 MARKING.....	31
12.1 Marking to be applied.....	31
12.2 Additional marking	31
13 PROTECTION	31
Annex A (normative).....	32
Annex ZA (informative)	33
Bibliography	34

Foreword

This document (EN 10216-3:2002) has been prepared by Technical Committee ECISS/TC 29, "Steel tubes and fittings for steel tubes", the secretariat of which is held by UNI.

This European Standard shall be given the status of a national standard, either by publication of an identical text or by endorsement, at the latest by November 2002, and conflicting national standards shall be withdrawn at the latest by November 2002.

This document has been prepared under a mandate given to CEN by the European Commission and the European Free Trade Association, and supports essential requirements of EU Directive(s).

For relationship with EU Directive(s), see informative annex ZA, which is an integral part of this document.

Other Parts of EN 10216 are:

- Part 1 : Non-alloy steel tubes with specified room temperature properties
- Part 2 : Non-alloy and alloy steel tubes with specified elevated temperature properties
- Part 4 : Non-alloy and alloy steel tubes with specified low temperature properties
- Part 5 : Stainless steel tubes

Another European Standard series covering tubes for pressure purposes is:

EN 10217: Welded steel tubes for pressure purposes

According to the CEN/CENELEC Internal Regulations, the national standards organizations of the following countries are bound to implement this European Standard: Austria, Belgium, Czech Republic, Denmark, Finland, France, Germany, Greece, Iceland, Ireland, Italy, Luxembourg, Malta, Netherlands, Norway, Portugal, Spain, Sweden, Switzerland and the United Kingdom.

Foreword to amendment A1

This document (EN 10216-3:2002/A1:2004) has been prepared by Technical Committee ECISS /TC 29 "Steel tubes and fittings for steel tubes", the secretariat of which is held by UNI.

This European Standard shall be given the status of a national standard, either by publication of an identical text or by endorsement, at the latest by September 2004, and conflicting national standards shall be withdrawn at the latest by September 2004.

This document has been prepared under a mandate given to CEN by the European Commission and the European Free Trade Association, and supports essential requirements of EU Directive 97/23/EC.

For relationship with EU Directive 97/23/EC, see informative annex ZA, which is an integral part of this document.

According to the CEN/CENELEC Internal Regulations, the national standards organizations of the following countries are bound to implement this European Standard: Austria, Belgium, Cyprus, Czech Republic, Denmark, Estonia, Finland, France, Germany, Greece, Hungary, Iceland, Ireland, Italy, Latvia, Lithuania, Luxembourg, Malta, Netherlands, Norway, Poland, Portugal, Slovakia, Slovenia, Spain, Sweden, Switzerland and United Kingdom.

1 SCOPE

This Part of EN 10216 specifies the technical delivery conditions in two test categories for seamless tubes of circular cross section, made of weldable alloyed fine grained steel.

2 NORMATIVE REFERENCES

This European Standard incorporates by date or undated reference, provisions from other publications. These normative references are cited at the appropriate places in the text and the publications are listed hereafter. For date references, subsequent amendments to or revisions of, any of these publications apply to this European Standard only when incorporated in it by amendment or revision. For undated references the latest edition of the publication referred to applies (including amendments).

The requirements of this European Standard rule when they differ from those in the standards and documents referred to below:

EN 10002-1, *Metallic materials - Tensile testing - Part 1: Method of test (at ambient temperature)*.

EN 10002-5, *Metallic materials - Tensile testing - Part 5: Method of testing (at elevated temperature)*.

EN 10020, *Definitions and classification of grades of steel*.

EN 10021, *General technical delivery requirements for steel and iron products*.

EN 10045-1, *Metallic materials - Charpy impact test - Part 1: Test method*.

EN 10052, *Vocabulary of heat treatment terms for ferrous products*.

EN 10204, *Metallic products - Types of inspection documents*.

EN 10027-1, *Designation systems for steels - Part 1 : Steel names, principle symbols*.

EN 10027-2, *Designation systems for steels Part 2 : Numerical systems*.

ENV 10220, *Seamless and welded steel tubes - Dimensions and masses per unit length*

EN 10233, *Metallic materials - Tubes - Flattening test*.

EN 10234, *Metallic materials - Tubes - Drift expanding test*.

EN 10236, *Metallic materials - Tubes - Ring expanding test*.

EN 10237, *Metallic materials - Tubes - Ring tensile test*.

EN 10246-1, *Non-Destructive Testing of steel tubes Part 1 : Automatic electromagnetic testing of seamless and welded (except submerged arc welded) ferromagnetic steel tubes for verification of hydraulic leak-tightness*.

EN 10246-5, *Non-Destructive Testing of steel tubes – Part 5: Automatic full peripheral magnetic transducer/flux leakage testing of seamless and welded (except submerged arc-welded) ferromagnetic steel tubes for the detection of longitudinal imperfections*.

EN 10246-6, *Non-Destructive Testing of steel tubes - Part 6: Automatic full peripheral ultrasonic testing of seamless steel tubes for the detection of transverse imperfections*.

EN 10246-7, *Non-Destructive Testing of steel tubes - Part 7 : Automatic full peripheral ultrasonic testing of seamless and welded (except submerged arc welded) steel tubes for the detection of longitudinal imperfections*.

EN 10246-14, *Non-Destructive Testing of steel tubes - Part 14: Automatic ultrasonic testing of seamless and welded (except submerged arc welded) steel tubes for the detection of laminar imperfections.*

EN 10256, *Non-Destructive Testing of steel tubes - Qualification and competence of level 1 and level 2 NDT personnel.*

EN ISO 377, *Steel and steel products - Location and preparation of samples and test pieces for mechanical testing (ISO 377:1997)*

EN ISO 2566-1, *Steel - Conversion of elongation values – Part 1: Carbon and low-alloy steels (ISO 2566-1:1984)*

prEN 10168¹⁾, *Iron and steel products - Inspection documents - List of information and description*

prEN 10266¹⁾, *Steel tubes, fittings and structural hollow sections - Symbols and definition of terms for use in product standards*

EURONORM 103²⁾, *Microscopic determination of ferritic grain size of steel.*

ISO 14284, *Steel and iron - Sampling and preparation of samples for the determination of chemical composition*

CR 10260, *Designation systems for steel - Additional symbols*

CR 10261, *ECISS Information Circular IC 11 - Iron and steel - Review of available methods of chemical analysis.*

3 TERMS AND DEFINITIONS

For the purposes of this Part of EN 10216, the terms and definitions given in EN 10020, EN 10021, EN 10052, prEN 10266 and the following apply:

3.1

test category

classification that indicates the extent and level of inspection and testing.

3.2

employer

organisation for which a person works on a regular basis.

NOTE The employer may be either the tube manufacturer or supplier or a third party organisation providing Non-Destructive Testing (NDT) services.

3.3

fine grain steel

steel having a ferritic grain size equal to or finer than 6 in accordance with EURONORM 103

1) In preparation; until this document is published as a European Standard, the corresponding national standard(s) should be agreed at the time of enquiry and order.

2) Until this EURONORM is transformed into an European Standard, it can be implemented or the corresponding national standard may be agreed at the time of enquiry and order.

4 SYMBOLS

For the purpose of this Part of EN 10216, the symbols given in prEN 10266 and the following apply:

- d specified inside diameter;
- d_{\min} specified minimum inside diameter;
- T_{\min} specified minimum wall thickness;
- D_c calculated outside diameter;
- d_c calculated inside diameter;
- T_c calculated wall thickness;
- TC test category

5 CLASSIFICATION AND DESIGNATION

5.1 Classification

5.1.1 This Part of EN 10216 covers steel grades in four qualities (see Tables 2 and 4):

- the basic quality (P ... N, Q);
- the elevated temperature quality (P ... NH, QH);
- the low temperature quality (P ... NL1, QL, QL1);
- the special low temperature quality (P ... NL2, QL2).

5.1.2 In accordance with the classification system in EN 10020, the steel grades P275NL1, P355N, P355NH and P355NL1 are classified as alloy quality steels and the other steel grades are classified as alloy special steels.

5.2 Designation

5.2.1 For the tubes covered by this Part of EN 10216 steel the designation consists of:

- the number of this Part of EN 10216;

plus either:

- the steel name in accordance with EN 10027-1 and CR 10260;

or :

- the steel number allocated in accordance with EN 10027-2.

5.2.2 The steel name is designated by:

- the capital letter P for pressure purposes;
- the indication of the specified minimum yield strength for the lowest applicable wall thickness group expressed in megapascals, (Table 4);
- one of the additional symbols N, NH, NL1, NL2, Q, QH, QL, QL1 or QL2 (see 5.1.1, Tables 2 and 4).

6 INFORMATION TO BE SUPPLIED BY THE PURCHASER

6.1 Mandatory information

The following information shall be supplied by the purchaser at the time of enquiry and order :

- a) the quantity (mass or total length or number);
- b) the term "tube";
- c) the dimensions (outside diameter D and wall thickness T or a set of dimensions covered by option 10) (see Table 7);
- d) the designation of the steel grade in accordance with this Part of EN 10216 (see 5.2);
- e) the test category, except for P620 and P690 (see 9.3).

6.2 Options

A number of options are specified in this Part of EN 10216 and these are listed below. In the event that the purchaser does not indicate a wish to implement any of these options at the time of enquiry and order, the tubes shall be supplied in accordance with the basic specification (see 6.1).

- 1) Cold finishing (see 7.3.2).
- 2) Restriction on copper and tin content (see Table 2).
- 3) Product analysis (see 8.2.2).
- 4) Verification of elevated temperature properties of NH-grades (see 8.3.2).
- 5) Verification of elevated temperature properties of NL- and QL-grades (see 8.3.2).
- 6) Selection of leak-tightness test method (see 8.4.2.1).
- 7) Non-Destructive Testing for test category 2 tubes for detection of transverse imperfections (see 8.4.2.2)
- 8) Non-Destructive Testing for test category 2 tubes for the detection of laminar imperfections (see 8.4.2.2).
- 9) Special ends preparation (see 8.6).
- 10) Set of dimensions other than D and T (see 8.7.1).
- 11) Exact lengths (see 8.7.3).
- 12) The type of inspection document other than the standard document (see 9.2.1).
- 13) Additional impact test at test temperature different from standard test temperature (see Table 16).
- 14) Test pressure for hydrostatic leak-tightness test (see 11.8.1).
- 15) Wall thickness measurement away from the ends (see 11.9)
- 16) Non-Destructive Testing method (see 11.11.1)
- 17) Additional marking (see 12.2).
- 18) Protection (see clause 13).

6.3 Examples of an order

500 m of seamless tube with an outside diameter of 168,3 mm, a wall thickness of 4,5 mm in accordance with EN 10216-3, made of steel grade P355N, test category 1, with a 3.1.C inspection certificate in accordance with EN 10204:

500 m – Tube – 168,3 x 4,5 – EN 10216-3 – P355N – TC1 – Option 12: 3.1.C

7 MANUFACTURING PROCESS

7.1 Steelmaking process

The steelmaking process is at the discretion of the manufacturer.

7.2 Deoxidation process

Steels shall be fully killed and be made to a fine grain practice (see 3.3).

7.3 Tube manufacture and delivery conditions

7.3.1 All NDT activities shall be carried out by qualified and competent level 1,2 and/or 3 personnel authorised to operate by the employer.

The qualification shall be in accordance with EN 10256 or, at least, an equivalent to it.

It is recommended that the level 3 personnel be certified in accordance with EN 473 or, at least, an equivalent to it.

The operating authorisation issued by the employer shall be in accordance with a written procedure.

NDT operations shall be authorised by level 3 NDT individual approved by the employer.

NOTE The definition of level 1, 2 and 3 can be found in appropriate Standards, e.g. EN 473 and EN 10256

7.3.2 The tubes shall be manufactured by a seamless process.

Unless option 1 is specified, the tubes may be either hot or cold finished at the discretion of the manufacturer. The terms " hot finished " and " cold finished " apply to the condition of the tube before it is heat treated in accordance with 7.3.3.

Option 1: *The tubes shall be cold finished before heat treatment.*

7.3.3 The tubes shall be supplied in the relevant heat treatment conditions as specified in Table 1 and Table 4.

Table 1 — Forming operation and delivery condition

Forming operation	Heat treatment condition	Symbol for the delivery condition
Hot finished	Normalised ^{a b}	+N
	Quenched and tempered	+QT
Hot rolled + cold finished	Normalised ^b	+N
	Quenched and tempered	+QT
^a See 7.3.4		
^b See 7.3.5		

7.3.4 In case of steel grade P355N and P355NH normalising may be replaced by normalising forming.

7.3.5 For steel grade P460 it may be necessary to apply delayed cooling or additional tempering after normalising. For N-steel grades accelerated cooling after austenitizing may be necessary in order to achieve the intended structure and material properties in case of wall thickness above 25 mm or $T/D > 0,15$

In both cases, the decision shall be left to the discretion of the manufacturer but shall be stated to the customer at the time of enquiry and order. Steel tubes treated with accelerated cooling shall be designated by the steel name supplemented by the symbol "+QT".

8 REQUIREMENTS

8.1 General

When supplied in a delivery condition indicated in clause 7.3 and inspected in accordance with clauses 9, 10 and 11, the tubes shall conform to with the requirements of this Part of EN 10216.

In addition, the general technical delivery requirements specified in EN 10021 shall apply.

Tubes shall be suitable for hot and cold bending provided the bending is carried out in an appropriate manner.

When tubes are specified in the order by d , d_{\min} or T_{\min} the following equations, with all terms in mm, shall apply for the calculation of outside diameter D_c , inside diameter d_c and wall thickness T_c , instead of D , d and T for the relevant requirements in clauses 7.3.5, 8.4.1.4, 10.2.2.2, 11.3, 11.8.1, 11.9, 11.11.4, 12.1 and Table 1, footnote c, Tables 4, 5, 6, 7, 10, 12, 15 and 16:

$$D_c = d + 2T \quad (1)$$

$$D_c = d_{\min} + \frac{\text{tolerance} \cdot \text{of} \cdot d_{\min}}{2} + 2T \quad (2)$$

$$d_c = d_{\min} + \frac{\text{tolerance} \cdot \text{of} \cdot d_{\min}}{2} \quad (3)$$

$$T_c = T_{\min} + \frac{\text{tolerance} \cdot \text{of} \cdot T_{\min}}{2} \quad (4)$$

For tolerance see Tables 10, 11 and 12.

8.2 Chemical composition

8.2.1 Cast analysis

The cast analysis reported by the steel producer shall apply and conform to the requirements of Table 2.

NOTE When welding tubes produced in accordance with this Part of EN 10216, account should be taken of the fact that the behaviour of the steel during and after welding is dependent not only on the steel, but also on the applied heat treatment and the conditions of preparing for and carrying out the welding.

8.2.2 Product analysis

Option 3: A product analysis for the tubes shall be supplied.

Table 3 specifies the permissible deviations of the product analysis from the specified limits on cast analysis given in Table 2.

8.3 Mechanical properties

8.3.1 The mechanical properties of the tubes shall conform to the requirements in Tables 4, 5, 6, 7, Annex A, and in clauses 11.3, 11.4, 11.5 and 11.6.

8.3.2 The elevated temperature properties given in Tables 5 and 6 shall be verified for steel grade P620QH and P690QH at 300 °C.

Option 4: *Elevated temperature properties given in Tables 5 and 6 shall be verified for NH-grades at 400 °C.*

The properties at elevated temperature given in Tables 5 and 6 for steel grades P355NH, P460NH, P620QH and P690QH, apply for the corresponding low and special low temperature quality steels if option 5 is specified.

The properties at the elevated temperature given in Annex A for steel grades P275NL1 and P275NL2 apply, if option 5 is specified

Option 5: *Elevated temperature properties given in Tables 5, 6 and Annex A shall be verified for NL- and QL-grades at the highest temperature for which a value is given.*

Table 2 — Chemical composition (cast analysis) ^a, in % by mass

Steel grade	Steel number	C	Si	Mn	P	S	Cr	Mo	Ni	Al _{tot} ^b	Cu	N	Nb	Ti	V	Nb+Ti+V	
		max	max		max	max	max	max	max	min	max	max	max	max	max	max	max
P275NL1	1.0488	0,16	0,40	0,50 to 1,50	0,025	0,020	0,30 ^c	0,08 ^c	0,50	0,020	0,30 ^{c,d}	0,020	0,05	0,040	0,05	0,05	
P275NL2	1.1104				0,015												
P355N	1.0562	0,20	0,50	0,90 to 1,70	0,025	0,020	0,30 ^c	0,08 ^c	0,50	0,020	0,30 ^{c,d}	0,020	0,05	0,040	0,10	0,12	
P355NH	1.0565																
P355NL1	1.1106	0,18															
P355NL2	1.0566				0,015												
P460N	1.8905	0,20	0,60	1,00 to 1,70	0,025	0,020	0,30	0,10	0,80	0,020	0,70 ^e	0,020	0,05	0,040	0,20	0,22	
P460NH	1.8935																
P460 NL1	1.8915																
P460NL2	1.8918				0,015												
P620Q	1.8876	0,20	0,60	1,00 to 1,70	0,025	0,020	0,30	0,10	0,80	0,020	0,30 ^d	0,020	0,05	0,040	0,20	0,22	
P620QH	1.8877																
P620QL	1.8890				0,015												
P690Q	1.8879	0,20	0,80	1,20 to 1,70	0,025	0,015	1,50	0,70	2,50	0,020	0,30 ^d	0,015	0,06	0,05	0,12		
P690QH	1.8880																
P690QL1	1.8881																
P690QL2	1.8888				0,020	0,010											

^a Elements not included in this Table shall not be intentionally added to the steel without the agreement of the purchaser, except for elements which may be added for finishing the cast. All appropriate measures shall be taken to prevent the addition of undesirable elements from scrap or other materials used in the steel making process.

^b $Al/N \geq 2$, if nitrogen is fixed by niobium, titanium or vanadium the requirements for Al_{tot} and Al/N do not apply.

^c The sum of the percentage by mass of the three elements chromium, copper and molybdenum shall not exceed 0,45 %.

^d **Option 2:** in order to facilitate subsequent forming operation, an agreed maximum copper content lower than indicated and an agreed specified maximum tin content shall apply.

^e If the percentage by mass of copper exceeds 0,30 %, the percentage by mass of nickel shall be at least half the percentage by mass of copper.

Table 3 — Permissible deviations of the product analysis from specified limits on cast analysis given in Table 2

Element	Limiting value for the cast analysis in accordance with Table 2 % by mass	Permissible deviation of the product analysis % by mass
C	$\leq 0,20$	+ 0,02
Si	$\leq 0,40$	+ 0,05
	> 0,40 to 0,80	+ 0,06
Mn	$\leq 1,70$	+ 0,10 - 0,05
P	$\leq 0,025$	+ 0,005
S	$\leq 0,015$	+ 0,003
	> 0,015 $\leq 0,020$	+ 0,005
Al	$\geq 0,020$	- 0,005
Cr	$\leq 0,30$	+ 0,05
	> 0,30 to $\leq 1,50$	+ 0,10
Cu	$\leq 0,70$	+ 0,05
Mo	$\leq 0,35$	+ 0,03
	> 0,35 to $\leq 0,70$	+ 0,04
N	$\leq 0,020$	+ 0,002
Nb	$\leq 0,06$	+ 0,005
Ni	$\leq 2,50$	+ 0,05
Ti	$\leq 0,05$	+ 0,01
V	$\leq 0,10$	+ 0,01
	> 0,10 to $\leq 0,20$	+ 0,02

Table 4 — Mechanical properties at room temperature

Steel grade		Heat Treatment condition	Tensile properties						Elongation ^a A min. l t (%)					
Steel name	Steel number		Upper yield strength or proof strength R_{eH} or $R_{p0.2}$ min. for wall thickness T in mm		Tensile strength R_m for wall thickness T in mm		Tensile strength R_m for wall thickness T in mm							
			≤ 12	> 12 to ≤ 20	> 20 to ≤ 40	> 40 to ≤ 50		> 50 to ≤ 65	> 65 to ≤ 80	> 80 to ≤ 100	≤ 20	> 20 to ≤ 40	> 40 to ≤ 65	> 65 to ≤ 100
P 275 NL 1	1.0488	+N	275	265	255	245	235	390 to 530	390 to 510	360 to 480	24	22		
P 275 NL 2	1.1104													
P 355 N	1.0562	+N ^b	355	345	325	315	305	490 to 650	490 to 630	450 to 590	22	20		
P 355 NH	1.0565													
P 355 NL 1	1.0566	+N	460	450	440	425	410	400	560 to 730	490 to 690	19	17		
P 355 NL 2	1.1106													
P 460 N	1.8905	+N ^c	620	580	500	540	500	740 to 930	690 to 860	630 to 800	16	14		
P 460 NH	1.8935													
P 460 NL 1	1.8915													
P 460 NL 2	1.8918													
P 620 Q	1.8876	+QT	690	650	580	615	580	770 to 960	720 to 900	670 to 850	16	14		
P 620 QH	1.8877													
P 620 QL	1.8890													
P 690 Q	1.8879	+QT	690	650	580	615	580	770 to 960	720 to 900	670 to 850	16	14		
P 690 QH	1.8880													
P 690 QL 1	1.8881													
P 690 QL 2	1.8888		690	650	615	580	540	770 to 960	700 to 960	680 to 860				

^a l = longitudinal; t = transverse.

^b See 7.3.4.

^c See 7.3.5.

* 1 MPa = 1 N/mm²

Table 5 — Minimum 0,2 %-proof strength ($R_{p0,2}$) at elevated temperature ^a

Steel grade		Wall thickness T mm	$R_{p0,2}$ minimum MPa * at a temperature of °C									
Steel name	Steel number		100	150	200	250	300	350	400			
P355NH	1.0565	≤ 20	304	284	255	235	216	196	167			
		> 20 to ≤ 50	294	275	255	235	216	196	167			
		> 50 to ≤ 65	284	265	245	226	206	186	157			
		> 65 to ≤ 80	275	255	235	216	196	177	147			
		> 80 to ≤ 100	265	245	226	206	186	167	137			
P460NH	1.8935	≤ 12	402	373	343	314	294	265	235			
		> 12 to ≤ 20	392	363	343	314	294	265	235			
		> 20 to ≤ 50	382	353	333	304	284	255	226			
		> 50 to ≤ 65	373	343	324	294	275	245	216			
		> 65 to ≤ 80	363	333	314	284	265	235	206			
P620QH	1.8877	> 80 to ≤ 100	353	324	304	275	255	226	196			
		≤ 20	490	480	470	460	450	450	--			
		> 20 to ≤ 40	470	460	450	440	430	430	--			
P690QH	1.8880	> 40 to ≤ 65	430	420	410	400	390	390	--			
		≤ 20	590	580	570	560	550	550	--			
		> 20 to ≤ 40	550	540	530	520	510	510	--			
		> 40 to ≤ 65	510	500	490	480	470	470	--			
		> 65 to ≤ 80	490	480	470	460	450	450	--			
		> 80 to ≤ 100	450	440	430	420	410	410	--			

^a See 8.3.2

* 1 MPa = 1 N/mm²

Table 6 — Minimum tensile strength R_m at elevated temperature ^a

Steel grade		Wall thickness T mm	R _m minimum MPa * at a temperature of °C									
Steel name	Steel number		100	150	200	250	300	350	400	450	500	550
P355 NH	1.0565	≤ 30	440	430	410	410	410	400	390	390	380	370
		> 30 to ≤ 50	420	410	390	390	390	380	370	370	360	350
		> 50 to ≤ 80	400	390	370	370	370	360	350	340	340	340
P460NH	1.8935	> 80 to ≤ 100	390	380	360	360	360	350	340	340	340	340
		≤ 30	510	490	480	480	480	470	460	460	450	440
		> 30 to ≤ 50	490	470	460	460	460	450	440	440	430	420
P620QH	1.8877	> 50 to ≤ 80	480	460	450	450	450	440	430	430	420	420
		> 80 to ≤ 100	470	450	440	440	440	430	430	420	420	420
		≤ 20	640	620	600	600	600	600	600	600	600	600
P690QH	1.8880	> 20 to ≤ 40	600	580	560	560	560	560	560	560	560	560
		> 40 to ≤ 65	540	520	500	500	500	500	500	500	500	500
		≤ 20	710	690	670	670	670	670	670	670	670	670
		> 20 to ≤ 40	660	640	620	620	620	620	620	620	620	620
		> 40 to ≤ 80	610	590	570	570	570	570	570	570	570	570
		> 80 to ≤ 100	580	560	540	540	540	540	540	540	540	540

^a See 8.3.2.

* 1 MPa = 1 N/mm²

Table 7 — Minimum impact energy

Steel grades		Wall thickness T mm	Minimum average impact energy KV J for													
			longitudinal direction							transverse direction						
Steel name	Steel number		-50	-40	-30	-20	-10	0	+20	-50	-40	-30	-20	-10	0	+20
P355N P355NH P460N P460NH	1.0562 1.0565 1.8905 1.8935	≤ 40	-	-	-	40	43	47	55	-	-	-	27	31	35	39
P620Q P620QH P690Q P690QH	1.8876 1.8877 1.8879 1.8880	> 40 to ≤ 65	-	-	-	-	40	45	50	-	-	-	-	27	31	35
P275NL1 P355NL1 P460NL1 P620QL P690QL1	1.0488 1.0566 1.8915 1.8890 1.8881	≤ 40	-	40	47	53	60	65	70	-	27	31	35	39	43	47
P275NL2 P355NL2 P460NL2 P690QL2	1.1104 1.1106 1.8918 1.8888	≤ 40	40	50	60	70	80	90	100	27	33	40	47	53	60	70
		> 40 to ≤ 65	-	40	50	60	70	80	90	-	27	33	40	47	53	60

8.4 Appearance and internal soundness

8.4.1 Appearance

8.4.1.1 The tubes shall be free from external and internal surface defects, that can be detected by visual examination.

8.4.1.2 The internal and external surface finish of the tubes shall be typical of the manufacturing process and, where applicable, the heat treatment employed. Normally the finish and surface condition shall be such that any surface imperfections requiring dressing can be identified.

8.4.1.3 It shall be permissible to dress, only by grinding or machining, surface imperfections provided that, after doing so, the wall thickness in the dressed area is not less than the specified minimum wall thickness. All dressed areas shall blend smoothly into the contour of the tube.

8.4.1.4 Any surface imperfection, which is demonstrated to be deeper than 5 % of the wall thickness T or 3 mm whichever is the smaller, shall be dressed.

This requirement does not apply to surface imperfection with a depth equal or less 0,3 mm

8.4.1.5 Surface imperfections which encroach on the specified minimum wall thickness shall be considered defects and tubes containing these shall be deemed not to comply with this Part EN 10216.

8.4.2 Internal soundness

8.4.2.1 Leak-tightness

The tubes shall pass a hydrostatic test (see 11.8.1) or electromagnetic test (see 11.8.2) for leak tightness.

Unless option 6 is specified, the choice of the test method is at the discretion of the manufacturer.

Option 6: *The test method for verification of leak-tightness in accordance with 11.8.1 or 11.8.2 is specified by the purchaser.*

8.4.2.2 Non-Destructive testing

The tubes of test category 2 shall be subjected to a Non-Destructive testing for the detection of longitudinal imperfections, in accordance with 11.11.1.

Option 7: *The tubes of test category 2 shall be subjected to a Non-Destructive testing for the detection of transverse imperfections in accordance with 11.11.2.*

Option 8: *The tubes of test category 2 shall be subjected to a Non-Destructive testing for the detection of the laminar imperfections in accordance with 11.11.3.*

8.5 Straightness

The deviation from straightness of any tube length L shall not exceed $0,0015 L$. Deviations from straightness over any one metre length shall not exceed 3 mm.

8.6 Preparation of ends

Tubes shall be delivered with square cut ends. The ends shall be free from excessive burrs.

Option 9: *The tubes shall be delivered with bevelled ends (see figure 1). The bevel shall have an angle α of 30° with a root face C of $1,6 \text{ mm} \pm 0,8 \text{ mm}$, except that for wall thickness T greater than 20 mm, an alternative bevel may be specified*

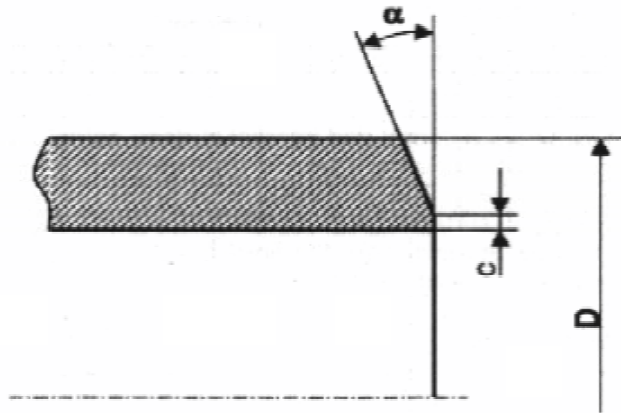

Figure 1 — Tube end bevel

8.7 Dimensions, masses and tolerances

8.7.1 Diameter and wall thickness

Unless option 10 is specified, tubes shall be delivered by outside diameter D and wall thickness T .

Preferred outside diameters D and wall thicknesses T have been selected from ENV 10220 and are given in Table 8.

NOTE Dimensions which are different from those in Table 8 may be agreed.

Option 10: *The tubes shall be delivered to one of the following sets of dimensions as specified at the time of enquiry and order:*

- outside diameter D and minimum wall thickness T_{\min} ;
- inside diameter d and wall thickness T for $d \geq 220$ mm;
- inside diameter d and minimum wall thickness T_{\min} for $d \geq 220$ mm;
- minimum inside diameter d_{\min} and wall thickness T for $d_{\min} \geq 220$ mm;
- minimum inside diameter d_{\min} and minimum wall thickness T_{\min} for $d_{\min} \geq 220$ mm.

Table 8 — Preferred dimensions

dimensions in mm

Outside diameter D			Wall thickness T																				
Series a			1,6	1,8	2	2,3	2,6	2,9	3,2	3,6	4	4,5	5	5,6	6,3	7,1	8	8,8	10	11	12,5	14,2	
1	2	3																					
10,2																							
	12																						
	12,7																						
13,5																							
	14																						
	16																						
17,2																							
	18																						
	19																						
	20																						
21,3																							
	22																						
	25																						
	25,4																						
26,9																							
	30																						
	31,8																						
	32																						
33,7																							
	35																						
	38																						
	40																						
42,4																							
	44,5																						
48,3																							
	51																						
	54																						
	57																						
60,3																							
	63,5																						
	70																						
	73																						
76,1																							
	82,5																						
88,9																							
	101,6																						
	108																						
114,3																							
	127																						
	133																						
139,7																							
	141,3																						
	152,4																						
	159																						
168,3																							
	177,8																						
	193,7																						
219,1																							
	244,5																						
273																							
323,9																							
355,6																							
406,4																							
457																							
508																							
	559																						
610																							
	660																						
711																							

Licensed Copy: sheffieldun sheffieldun, na, Tue Oct 10 03:23:20 BST 2006, Uncontrolled Copy, (c) BSI

Table 8: Continues

dimensions in mm

Outside diameter D			Wall thickness T																		
series ^a			16	17,5	20	22,2	25	28	30	32	36	40	45	50	55	60	65	70	80	90	100
1	2	3																			
10,2																					
	12																				
	12,7																				
13,5																					
		14																			
	16																				
17,2																					
		18																			
	19																				
	20																				
21,3																					
		22																			
	25																				
		25,4																			
26,9																					
		30																			
	31,8																				
	32																				
33,7																					
		35																			
	38																				
	40																				
42,4																					
		44,5																			
48,3																					
	51																				
		54																			
	57																				
60,3																					
	63,5																				
	70																				
		73																			
76,1																					
		82,5																			
88,9																					
	101,6																				
		108																			
114,3																					
	127																				
	133																				
139,7																					
		141,3																			
		152,4																			
		159																			
168,3																					
		177,8																			
		193,7																			
219,1																					
		244,5																			
273																					
323,9																					
355,6																					
406,4																					
457																					
508																					
		559																			
610																					
		660																			
711																					

^a series 1 = diameter for which all the accessories needed for the construction of piping system are standardised;
series 2 = diameter for which not all the accessories are standardised;
series 3 = diameter for special application for which very few standardised accessories exist.

Licensed Copy: sheffieldun sheffieldun, na, Tue Oct 10 03:23:20 BST 2006, Uncontrolled Copy, (c) BSI

8.7.2 Mass

For the mass per unit length the provisions of ENV 10220 apply.

8.7.3 Lengths

Unless option 11 is specified, the tubes shall be delivered in random length. The delivery range shall be agreed at the time of enquiry and order.

Option 11: *The tubes shall be delivered in exact length and the length shall be specified at the time of enquiry and order. For tolerances see 8.7.4.2.*

8.7.4 Tolerances

8.7.4.1 Tolerances on diameter and thickness

The diameter and the wall thickness of the tubes shall be within the relevant tolerance limits given in Tables 9, 10, 11, 12 or 13.

Out of roundness is included in the tolerances on diameter and eccentricity is included in the tolerances on wall thickness.

Table 9 — Tolerances on outside diameter and wall thickness

Outside diameter D mm	Tolerances on D	Tolerances on T for a T/D ratio			
		≤ 0,025	> 0,025 ≤ 0,050	> 0,050 ≤ 0,10	> 0,10
D ≤ 219,1	± 1% or ± 0.5mm	± 12,5% or ± 0.4mm whichever is the greater			
D > 219,1	whichever is the greater	± 20%	± 15%	± 12,5%	± 10% ^a

Table 10 — Tolerances on inside diameter and on wall thickness

d	Tolerances on inside diameter		Tolerances on T for a T/d ratio				
	d _{min}		≤ 0,03	> 0,03 ≤ 0,06	> 0,06 ≤ 0,12	> 0,12	
± 1% or ± 2 mm whichever is the greater	+ 2% 0	+ 4 mm 0	Whichever is the greater	± 20%	± 15%	± 12,5%	± 10% ^{a)}

^a For outside diameters D ≥ 355,6 mm it is permitted to exceed the upper wall thickness locally by a further 5% of the wall thickness T

Table 11 — Tolerances on outside diameter and minimum wall thickness

Outside diameter D mm	Tolerances on D	Tolerances on T _{min} for a T _{min} /D ratio			
		≤ 0,02	> 0,02 ≤ 0,04	> 0,04 ≤ 0,09	> 0,09
D ≤ 219,1	± 1% or ± 0.5mm	+ 28% 0	or + 0.8 mm 0	whichever is the greater	
D > 219,1	whichever is the greater	+ 50% 0	+ 35% 0	+ 28% 0	+ 22% ^a 0

^{a)} For outside diameters D ≥ 355,6 mm it is permitted to exceed the upper wall thickness locally by a further 5% of the wall thickness T

Table 12 — Tolerances on inside diameter and minimum wall thickness

Tolerances on inside diameter		Tolerances on T_{\min} for a T_{\min}/d ratio		
d	d_{\min}	$\leq 0,05$	$> 0,05$ $\leq 0,1$	$> 0,1$
$\pm 1\%$ or ± 2 mm whichever is the greater	+2% 0 or + 4 mm 0 whichever is the greater	+ 35% 0	+ 28% 0	+ 22% ^a 0

^a For outside diameters $D \geq 355,6$ mm it is permitted to exceed the upper wall thickness locally by a further 5% of the wall thickness T

Table 13 — Tolerances on outside diameter and wall thickness for tube ordered cold finished

Tolerance on D	Tolerance on T
$\pm 0,5\%$ or $\pm 0,3$ mm whichever is the greater	$\pm 10\%$ or $\pm 0,2$ mm whichever is the greater

8.7.4.2 Tolerances on exact lengths

The tolerances for exact lengths shall be as given in Table 14.

Table 14 — Tolerances on exact lengths

Dimensions in mm

Length L	Tolerance on exact length
$2000 < L \leq 6000$	+10 0
$6000 < L \leq 12\ 000$	+15 0
$L > 12\ 000$	+ by agreement 0

9 INSPECTION**9.1 Types of inspection**

Conformity to the requirements of the order, for tubes in accordance with this Part of EN 10216, shall be checked by specific inspection.

When an inspection document 3.1.B is specified the material manufacturer shall state in the confirmation of the order whether he is operating according to a "quality-assurance system", certified by a competent Body established within the Community and having undergone a specific assessment for materials.

NOTE See the Directive 97/23/EC Annex I section 4.3 third paragraph.

9.2 Inspection documents

9.2.1 Types of inspection documents

Unless option 13 is specified, an inspection certificate 3.1.B, in accordance with EN 10204, shall be issued.

Option 13: One of the inspection documents 3.1.A, 3.1.C or 3.2 in accordance with EN 10204 shall be issued.

If an inspection document 3.1.A, 3.1.C or 3.2 is specified, the purchaser shall notify the manufacturer of the name and address of the organisation or person who is to carry out the inspection and produce the inspection document. In the case of the inspection report 3.2 it shall be agreed which party shall issue the certificate.

NOTE Document 3.1.A is not acceptable for compliance with the Directive 97/23/EC.

9.2.2 Content of inspection documents

The content of the inspection document shall be in accordance with prEN 10168.

In all types of inspection documents a statement on the conformity of the products delivered with the requirements of this specification and the order shall be included.

The inspection certificate or inspection report shall contain the following codes and information:

A	commercial transactions and parties involved;
B	description of products to which the inspection document applies;
C02-C03	direction of the test pieces and testing temperature;
C10-C13	tensile test;
C40-C43	impact test if applicable;
C60-C69	other tests;
C71-C92	chemical composition on cast analysis (product analysis if applicable);
D01	marking and identification, surface appearance, shape and dimensional properties;
D02-D99	leak-tightness test; NDT, material identification if applicable;
Z	validation.

In addition to the inspection document 3.1.B the manufacturer shall state the references to the certificate (see 9.1) of the appropriate "quality-assurance system", if applicable.

9.3 Summary of inspection and testing

The tubes shall be inspected and tested in test category 1 or test category 2 as specified in the order, except that P620 and P690 shall be tested to test category 2 (see 6.1).

Inspection and testing to be carried out are summarised in Table 15.

Table 15 — Summary of inspection and testing

Type of inspection and test		Frequency of testing	Refer to	Test category	
				1	2
Mandatory tests	Cast analysis	one per cast	8.2.1 - 11.1	X	X
	Tensile test at ambient temperature	one per sample tube	8.3.1 - 11.2.1	X	X
	Tensile test at elevated temperature (QH grades)		8.3.2 - 11.2.2	X	X
	Flattening test for $D < 600$ mm and T/D ratio $\leq 0,15$ but $T \leq 40$ mm or ^{a b}		8.3 - 11.3 - 11.4	X	X
	Ring tensile test for $D > 150$ mm and $T \leq 40$ mm		8.3 - 11.5 - 11.6	X	X
	Drift expanding test for $D \leq 150$ mm and $T \leq 10$ mm or ^{a b}			X	X
	Ring expanding test for $D \leq 114,3$ mm and $T \leq 12,5$ mm		8.3 - 11.7	X	X
	Impact test ^c	Each tube	8.4.2.1 - 11.8	X	X
	Leak tightness test	8.7 - 11.9		X	X
	Dimensional inspection	11.10		X	X
	Visual examination	Each tube	8.4.2.2 - 11.11.1	--	X
	NDT for the detection of longitudinal imperfections	tube	11.12	X	X
Material identification					
Optional tests	Product analysis (Option 3)	one per cast	8.2.2 - 11.1	X	X
	Tensile test at elevated temperature (NH,NL, QL-grades) (Options 4 or 5)	one per cast and same heat treatment condition	8.3 - 11.2.2	X	X
	Impact test at temperature other than standard test temperature (Option 13)	one per sample tube	11.7	X	X
	Wall thickness measurement away from tube ends (Option 15)	see 11.9		X	X
	NDT for the detection of transverse imperfections (Option 7)	Each tube	11.11.2	--	X
	NDT for the detection of laminar imperfections (Option 8)		11.11.3	--	X

^a The choice of flattening test or ring tensile test and of drift expanding test or ring expanding test is at the manufacturer's discretion.

^b Tests not applicable for steel grades P620 and P690.

^c **Option 13:** Additional to the testing at standard test temperature the impact test shall be performed at a temperature selected from those given in Table 7 for the relevant steel grade.

10 SAMPLING

10.1 Frequency of tests

10.1.1 Test unit

For normalised formed tubes a test unit shall comprise tubes of the same specified diameter and wall thickness, the same steel grade, the same cast, the same manufacturing process.

For tubes which are furnace heat treated a test unit shall comprise tubes of the same specified diameter and wall thickness, the same steel grade, the same cast, the same manufacturing process, subjected to the same finishing treatment in a continuous furnace or heat treated in the same furnace charge in a batch-type furnace.

The number of tubes per test unit shall conform to Table 16:

Table 16 — Number of tubes per test unit

Outside diameter D (mm)	Maximum number of tubes per test unit
$D \leq 114,3$	200
$114,3 < D \leq 323,9$	100
$D > 323,9$	50

10.1.2 Number of sample tubes per test unit

The following number of sample tubes shall be selected from each test unit.

- Test category 1: one sample tube
- Test category 2: two sample tubes; when the total number of tubes is less than 20, only one sample tube.

10.2 Preparation of samples and test pieces

10.2.1 Selection and preparation of samples for product analysis

Samples for product analysis shall be taken from the test pieces or samples for mechanical testing or from the whole wall thickness of the tube at the same location as the mechanical test samples in accordance with ISO 14284.

10.2.2 Location, orientation and preparation of samples and test pieces for mechanical tests

10.2.2.1 General

Samples and test pieces shall be taken at the tube ends and in accordance with the requirements of EN ISO 377.

10.2.2.2 Test pieces for tensile tests

The test pieces for the tensile tests at room temperature shall be prepared in accordance with EN 10002-1.

The test pieces for the tensile tests at elevated temperature shall be prepared in accordance with EN 10002-5.

At the manufacturer's discretion:

for tubes with an outside diameter $D \leq 219,1$ mm the test piece shall be either a full tube section or a strip section and shall be taken in a direction longitudinal to the axis of the tube;

for tubes with an outside diameter $D > 219,1$ mm the test piece shall either a machined test piece with circular cross section from an unflattened sample or a strip section and be taken in a direction either longitudinal or transverse to the axis of the tube.

10.2.2.3 Test pieces for the flattening test, ring tensile test, drift expanding test and ring expanding test

The test pieces for the flattening test, ring tensile test, drift expanding test and the ring expanding test shall consist of a full tube section in accordance with EN 10233, EN 10237, EN 10234 or EN 10236 respectively.

10.2.2.4 Test pieces for impact test

Three standard Charpy V-notch test pieces shall be prepared in accordance with EN 10045-1. If the wall thickness is such that standard test pieces cannot be produced without flattening of the section, then test pieces of width less than 10 mm, but not less than 5 mm shall be prepared; the largest obtainable width shall be used.

Where test pieces at least 5 mm width cannot be obtained, the tubes shall not be subject to impact testing.

The test pieces shall be taken transverse to the tube axis unless D_{\min} , as calculated by the following equation, is greater than the specified outside diameter, in which case longitudinal test pieces shall be used:

$$D_{\min} = (T-5) + [756,25 / (T-5)] \quad (5)$$

The test pieces shall prepared such that the axis of the notch is perpendicular to the surface of the tube, see figure 2

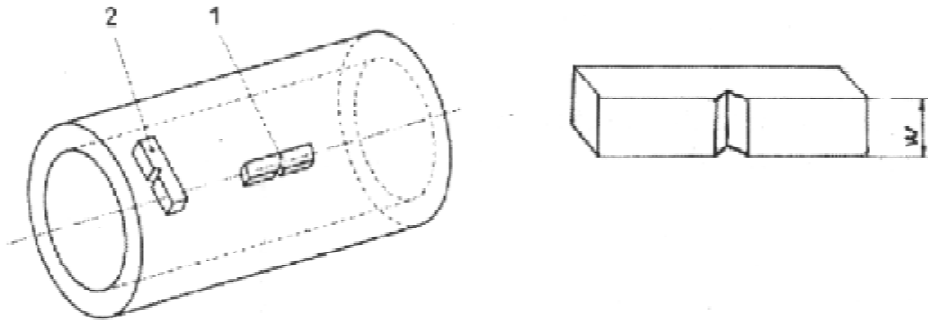

Key:

1 Longitudinal test piece

2 Transverse test piece

Figure 2 — Impact test piece orientation

11 TEST METHODS

11.1 Chemical analysis

The elements to be determined and reported shall be those specified in Table 2. The choice of a suitable physical or chemical analytical method for the analysis shall be at the discretion of the manufacturer. In cases of dispute the method used shall be agreed between manufacturer and the purchaser, taking into account CR10261.

11.2 Tensile test

11.2.1 Tensile test at room temperature

The test shall be carried out at room temperature in accordance with EN 10002-1, and the following determined:

- the tensile strength (R_m);
- the upper yield strength (R_{eH}) or if a yield phenomenon is not present the 0,2 % proof strength ($R_{p0,2}$);
- the percentage elongation after fracture with a reference to a gauge length (L_0) of $5,65 \cdot \sqrt{S_0}$; if a non-proportional test piece is used, the percentage elongation value shall be converted to the value for a gauge length $L_0 = 5,65 \cdot \sqrt{S_0}$ using the conversion Tables in EN ISO 2566-1.

11.2.2 Tensile test at elevated temperature

The test shall be carried out in accordance with EN 10002-5 at 400 °C or 300°C in accordance with the steel grade concerned and the following shall be determined:

- the 0,2% proof strength ($R_{p0,2}$);
- the tensile strength (R_m).

11.3 Flattening test

The test shall be carried out in accordance with EN 10233.

The tube section shall be flattened in a press until the distance H between the platens reaches the value given by the following equation:

$$H = \frac{(1 + C)}{C + (T/D)} \times T \quad (6)$$

where :

- H is the distance between platens, in mm, to be measured under load;
- D is the specified outside diameter, in mm;
- T is the specified wall thickness, in mm;
- C is the constant factor of deformation the value of which is:
 - 0,07 for steel grades with specified minimum yield strength ≤ 355 MPa;
 - 0,05 for steel grades with specified minimum yield strength ≥ 460 MPa.

After testing, the test piece shall be free from cracks or breaks. However, slight incipient cracks at its edges shall not be regarded as justification for rejection.

11.4 Ring tensile test

The test shall be carried out in accordance with EN 10237.

The tube section shall be subjected to strain in the circumferential direction until fracture occurs.

After fracture the test pieces shall not show any visible cracks without the use of magnifying aids (excluding the fracture point).

11.5 Drift expanding test

The test shall be carried out in accordance with EN 10234.

The tube section shall be expanded with a 60° conical tool until the percentage increase in outside diameter shown in Table 17 is reached.

Table 17 — Drift expanding test requirements

Steel grade	% increase in outside diameter for d/D^a		
	$\leq 0,6$	$> 0,6 \leq 0,8$	$> 0,8$
All steel grades	8	10	15
^a $d = D - 2T$			

After testing, the test piece shall be free from cracks or breaks. However, slight incipient cracks at its edges shall not be regarded as justification for rejection.

11.6 Ring expanding test

The test shall be carried out in accordance with EN 10236.

The tube section shall be expanded with a conical tool until it breaks. The surface outside the fracture zone shall be free from cracks or breaks. However, slight incipient cracks at its edges shall not be regarded as justification for rejection.

11.7 Impact test

11.7.1 The test shall be carried out in accordance with EN 10045-1, at - 20 °C for the basic and elevated temperature quality and at the relevant lowest temperature in accordance with Table 7 for the low and special low temperature quality.

11.7.2 The mean value of the three test pieces shall meet requirements given in Table 7. One individual value may be below the specified value, provided that it is not less than 70 % of that value.

11.7.3 If the width (W) of the test piece is less than 10 mm, the measured impact energy (KV_p) shall be converted to the calculated impact energy (KV_c) using the following equation:

$$KV_c = \frac{10 \times KV_p}{W} \quad (7)$$

where:

- KV_c is the calculated impact energy, in J;
- KV_p is the measured impact energy, in J;
- W is the width of the test piece, in mm.

The calculated impact energy KV_c shall conform to the requirements given in 11.7.2.

11.7.4 If the requirements of 11.7.2 are not met, then an additional set of three test pieces may be taken at the discretion of the manufacturer from the same sample and tested. To consider the test unit as conforming, after testing the second set, the following conditions shall be satisfied simultaneously:

the average value of the six tests shall be equal to or greater than the specified minimum average value;

not more than two of the six individual values may be lower than the specified minimum average value;

not more than one of the six individual values may be lower than 70 % of the specified minimum average value.

11.7.5 The dimensions in millimetres of the test pieces, the measured impact energy values and the resulting average value shall be reported.

11.8 Leak tightness test

11.8.1 Hydrostatic test

The hydrostatic test shall be carried out at a test pressure of 70 bar³⁾ or at a test pressure P calculated using the following equation, whichever is lower:

$$P = 20 \frac{S \times T}{D} \quad (8)$$

where :

3) 1 bar = 100 kPa.

EN 10216-3:2002 (E)

- P is the test pressure, in bar;
- D is the specified outside diameter, in mm;
- T is the specified wall thickness, in mm;
- S is the stress, in MPa, corresponding to 70 % of the specified minimum yield strength (see Table 4) for the steel grade concerned.

The test pressure shall be held for not less than 5 s for tubes with an outside diameter D less than or equal to 457 mm and for not less than 10 s for tubes with an outside diameter D greater than 457 mm.

The tube shall withstand the test without showing leakage or visible deformation.

NOTE This hydrostatic leak-tightness test is not a strength test.

Option 14: A test pressure different from that specified in 11.8.1 and corresponding to stresses below 90% of the specified minimum yield strength (see Table 4) for the steel grade concerned is specified.

11.8.2 Electromagnetic test

The test shall be carried out in accordance with EN 10246-1.

11.9 Dimensional inspection

Specified dimensions, including straightness, shall be verified.

The outside diameter shall be measured at tube ends. For tubes with outside diameter $D \geq 406,4$ mm, the diameter may be measured using a circumference tape.

Unless option 15 is specified the wall thickness shall be measured at both tube ends.

Option 15: The wall thickness shall be measured away from the tube ends in accordance with an agreed procedure.

11.10 Visual examination

Tubes shall be visually examined to ensure conformity to the requirements of 8.4.1.

11.11 Non-destructive testing

11.11.1 Tubes of test category 2 shall be subjected Non-Destructive Testing for the detection of longitudinal imperfections, in accordance with EN 10246-7, to acceptance level U2 sub-category C or EN 10246-5 acceptance level F2.

Unless option 16 is specified, the selection of the method is at the discretion of the manufacture.

Option 16: The test method is specified by the purchaser.

Regions at the tube ends not automatically tested shall either be subjected to manual/semi-automatic ultrasonic testing in accordance with EN 10246-7 to acceptance Level U 2, sub-category C, or be cropped off.

11.11.2 If option 7 is specified, the tubes shall be submitted to ultrasonic testing for the detection of transverse imperfections in accordance with EN 10246-6 to acceptance level U2 sub-category C.

11.11.3 If option 8 is specified, the tubes shall be submitted to ultrasonic testing for the detection of the laminar imperfections in accordance with EN 10246-14 to acceptance level U2.

11.11.4 For tubes ordered by minimum wall thickness T_{\min} (see option 10), the acceptance level shall apply to the calculated wall thickness T_c as determined in accordance with the formula stated in clause 8.

11.12 Material identification

Each tube made of steel grades P460 , P620 and P690 shall be tested by an appropriate method to ensure that the correct grade is being supplied.

11.13 Retests , sorting and reprocessing

For retest, sorting and reprocessing the requirements of EN 10021 shall apply.

12 MARKING

12.1 Marking to be applied

The marking shall be indelibly marked on each tube at least at one end. For tubes with outside diameter $D \leq 51$ mm the marking on tubes may be replaced by the marking on a label attached to the bundle or box.

The marking shall include the following information:

- the manufacturer's name or trade mark ;
- the number of this European standard and the steel name (see 5.2);
- the test category except for grade P 620 and P 690 (see 9.3);
- the cast number or a code number;
- the mark of the inspection representative;
- an identification number (e.g. order or item number) which permits the correlation of the product or delivery unit to the related documents.

Example of marking:

X - EN 10216-3 - P355N - TC1 - Y - Z₁ - Z₂

where:

- X is the manufacturer's mark;
- TC1 is the designation of the test category 1;
- Y is the cast number or a code number;
- Z₁ is the mark of the inspection representative;
- Z₂ is the identification number.

12.2 Additional marking

Option 17: Additional marking, as agreed upon at the time of enquiry and order, shall be applied.

13 PROTECTION

The tubes shall be delivered without a temporary protective coating.

Option 18: A temporary protective coating or durable coating and/or lining shall be applied.

Annex A (normative)

Elevated temperature properties for steel grades P275NL1 and NL2

Table A1 - Minimum 0,2 %- proof strength ^a

Wall thickness T mm	Rp _{0,2} (MPa) at a temperature of °C						
	100	150	200	250	300	350	400
≤ 20	255	235	206	186	157	137	118
> 20 to ≤ 50	245	226	206	186	157	137	118
> 50 to ≤ 65	235	216	196	177	147	127	108
> 65 to ≤ 80	226	206	186	167	137	117	98
> 80 to ≤ 100	216	196	177	157	127	108	88
^a see 8.3.2							

Table A.2 - Minimum tensile strength ^a

Wall thickness T mm	R _m (MPa) at a temperature of °C						
	100	150	200	250	300	350	400
≤ 30	340	330	310	310	310	300	290
> 30 to ≤ 50	320	310	290	290	290	280	270
> 50 to ≤ 80	300	290	270	270	270	260	250
> 80 to ≤ 100	290	280	260	260	260	250	240
^a see 8.3.2							

Annex ZA (informative)

Relationship between this European Standard and the Essential Requirements of EU Directive 97/23/EC

This European Standard has been prepared under a mandate given to CEN by the European Commission and the European Free Trade Association to provide a means of conforming to Essential Requirements of the New Approach Directive 97/23/EC.

Once this standard is cited in the Official Journal of the European Union under that Directive and has been implemented as a national standard in at least one Member State, compliance with the clauses of this standard given in Table ZA confers, within the limits of the scope of this standard, a presumption of conformity with the corresponding Essential Requirements of that Directive and associated EFTA regulations.

Table ZA-1 — Correspondence between this European Standard and the essential requirements of the EU Directive 97/23/EC

Clauses/sub-clauses of this EN	Essential Requirements (ERs) of the Directive 97/23/EC	Qualifying remarks/Notes
8.3	Annex I, 4.1a	Appropriate material properties
7.2 and 8.2 Table 5 and Table 6 Annex A	Annex I, 4.1c	Ageing
7.3 and 8.4	Annex I, 4.1d	Suitable for the processing procedures
9 and 10	Annex I, 4.3	Documentation

WARNING: Other requirements and other EU Directives may be applicable to the product(s) falling within the scope of this standard.

Bibliography

EN 473, *Non destructive testing - Qualification and certification of NDT personnel - General principles*

